

# BUTTERFLY DAMPER VALVE HIGH TEMPERATURE



# ARP INDUSTRY

VALVE TECHNOLOGY

## TYPE

# CSM11 – CSM21

 (Heavy duty)

**CSM11** bidirectional butterfly damper valves with controlled leakage are suitable for max. 600°C working temperature and low pressure. They are used extensively for gas isolation or control application.

These type of dampers are manufactured with one blade connected by two shafts. They are lightweight and cost-effective.

Single disc with seat against a fixed stop. Their construction allows easy maintenance with replacement of pushpacking and bearings. Mild steel or stainless steel construction.

Leakage classes in compliance with ANSI FCI 70-2. Actuation can be added to all sizes and flanges can be designed to suit customised requirements. Shop tested for proper mechanical operation.



**CSL20** Custom heavy duty round damper valves designed for isolation and low leakage applications.

Solid flanges are welded around a circular frame with drilling for standard or custom bolt hole patterns.

They are designed to maintain optimal efficiency in dusty applications and continuous service of particulate and corrosive fluegas.

They have a robust design with double shaft, double outside bearing and reinforced disc to ensure operation of severe fluid at elevated velocities. These damper valves provide very low leakage in critical industrial process control systems.

Available in coated carbon steel or stainless steel construction. Standard range extends to DN 3000.

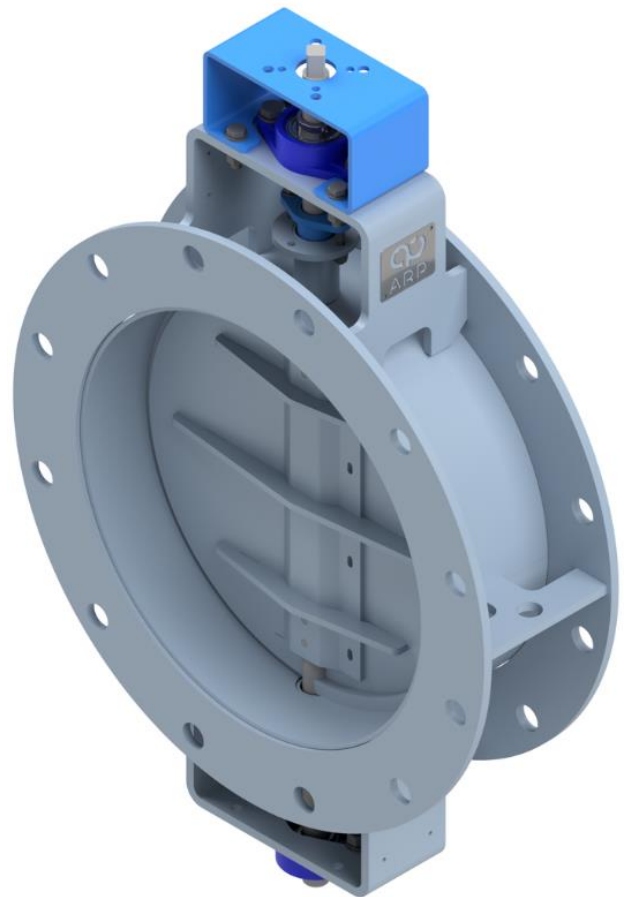

# Type: CSM11

## TECHNICAL CHARACTERISTICS:

- Diameter range DN150 ÷ DN1500
- Max Temperature 600°C
- Max pressure 0,5 barg
- Interception or modulating service
- Designed for 200 mm insulation
- Max Leakage Class III / IV (FCI 70-2)

## MATERIALS:

- CORTEN A
- Wear resistant steel
- Ferritic, austenitic, and duplex stainless steel

## SHAFT PACKING:

- Graphite braid packing
- Braid packing with lantern ring and air sealing
- Braid Packing air sealing shaft cleaning

## SEAT PACKING:

- No Seat
- Metal to Metal Seat
- Harmonic Stainless steel lamellas
- Soft Sealing

## APPLICABLE STANDARD:

- Design EN 593, EN 12516, ASME B16.34
- Flanges EN 1092-1, ASME B16.5,
- Testing EN12266, ANSI / FCI70-2

# Type: CSM21 (Heavy duty)

## TECHNICAL CHARACTERISTICS:

- Diameter range DN150 ÷ DN3000
- Max Temperature 600°C
- Max pressure up to 3 barg
- Interception or modulating service
- Designed for 200 mm insulation
- Max Leakage Class III / IV (FCI 70-2)

## MATERIALS:

- CORTEN A
- Wear resistant steel
- Ferritic, austenitic, and duplex stainless steel

## SHAFT PACKING:

- Graphite braid packing
- Braid packing with lantern ring and air sealing
- Braid Packing air sealing shaft cleaning

## SEAT PACKING:

- No Seat
- Metal to Metal Seat
- Harmonic Stainless steel lamellas
- Soft Sealing

## APPLICABLE STANDARD:

- Design EN 593, EN 12516, ASME B16.34
- Flanges EN 1092-1, ASME B16.5,
- Testing EN12266, ANSI / FCI70-2

# BLADE SEALING DESIGNS:

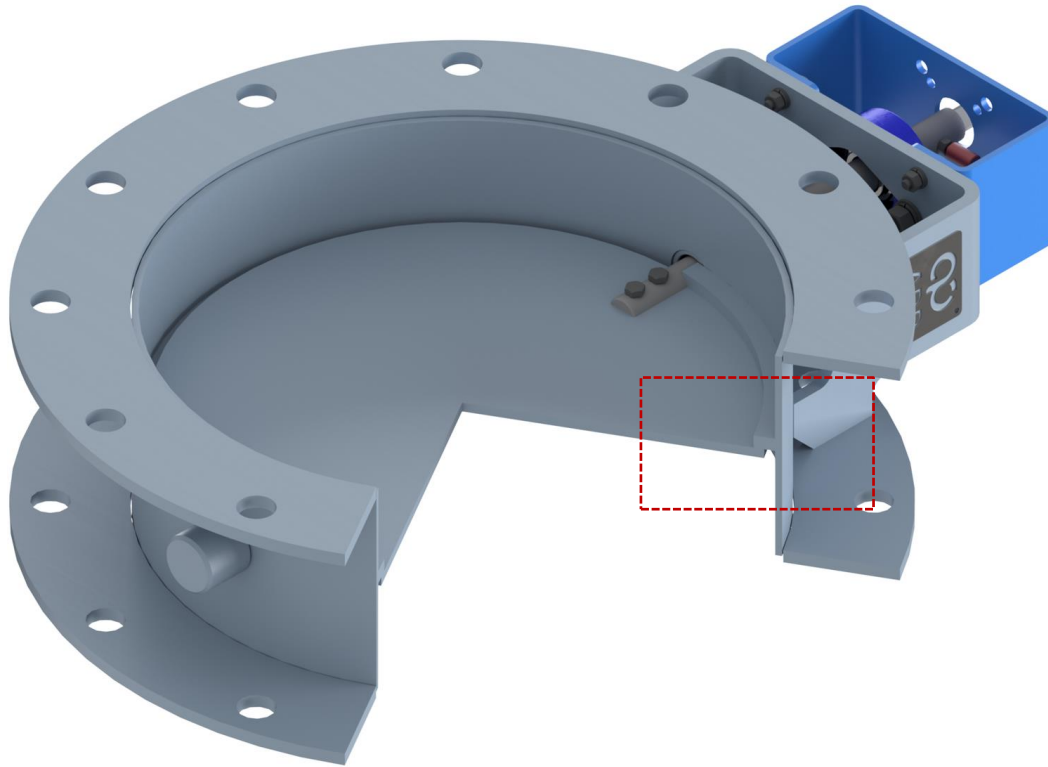

## NO SEAT

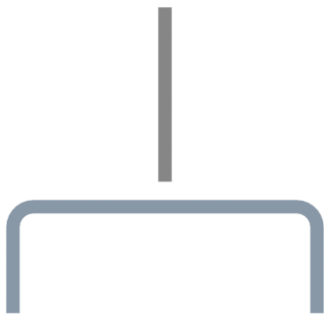

CODE BS1		
DIAMETER	CLASS	(FCI 70-2)
150 - 3000	I	Relative Tightness
-	-	-
-	-	-

No contact between disc and valve body.  
Relative tightness.  
Suitable when no specific tightness with closed disc is required.

## METAL / METAL SEAT

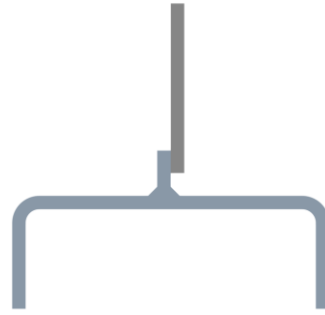

CODE BS2		
DIAMETER	CLASS	(FCI 70-2)
150 - 200	I	Relative Tightness
250 - 3000	II	< 0,5% Kvs
-	-	-

Metal seat with rigid rim between body and disc.  
This sealing option is widely used where a good shut off capability is required. It admits a percentage of leakage.

## HARMONIC STAINLESS STEEL LAMELLAS

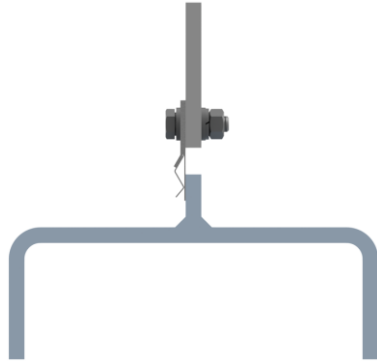

CODE BS3		
DIAMETER	CLASS	(FCI 70-2)
150 - 200	I	Relative Tightness
250 - 1500	II	< 0,5% Kvs
1550-3000	III	< 0,1% Kvs

Metal seat with lamella profile.  
Ideal for improved tightness requirements.  
It provides better strength and resilience.  
A degree of leakage is admitted.

## SOFT SEALING

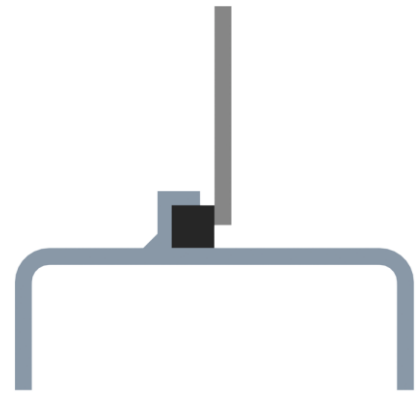

CODE BS4		
DIAMETER	CLASS	(FCI 70-2)
150 - 200	II	< 0,5% Kvs
250 - 1000	III	< 0,1% Kvs
1100 - 3000	III / IV	< 0,05% Kvs

Soft gasket or braided seat between disc and valve body.  
It is designed to cater an improved tightness class requirement.

Soft seat material depends on specific application. Understanding your process conditions is key to determining the right seat for your application.

If the selection is still unclear, speak with our engineer who is well versed in valve selection to help determine the right solution.

Our standard materials are as follows:

- FIBERGLASS BRAID
- GRAPHITE BRAID
- CERAMIC BRAID

Additional sealing materials are available upon request.

# SHAFT SEALING:

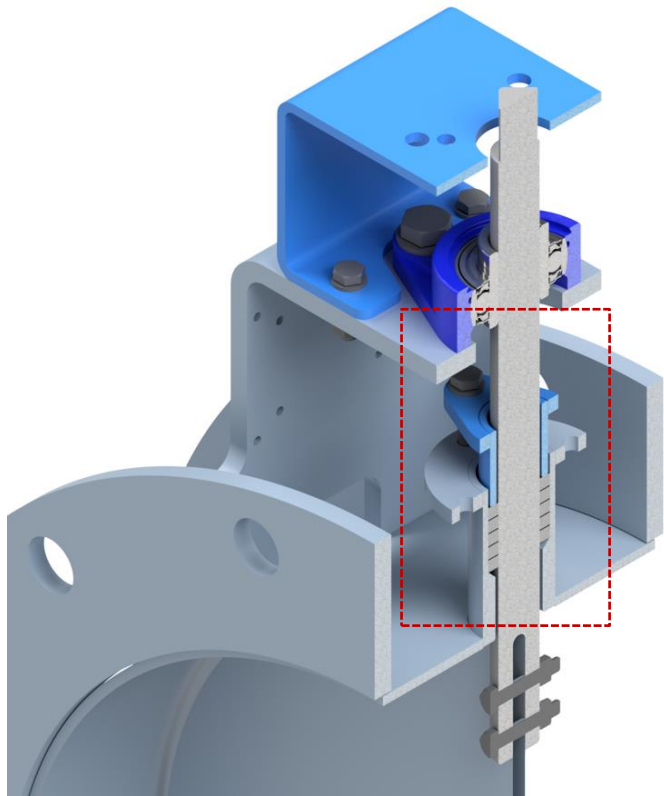

## STANDARD BRAID PACKING CODE SS02

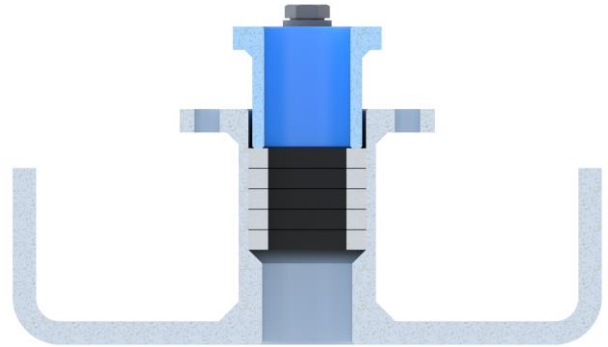

Seal tightness between the cover and the stem is achieved by pressing a pushpacking to fill the existing gap.

## BRAID PACKING WITH LANTERN RING AIR PURGE SEALS CODE SS03

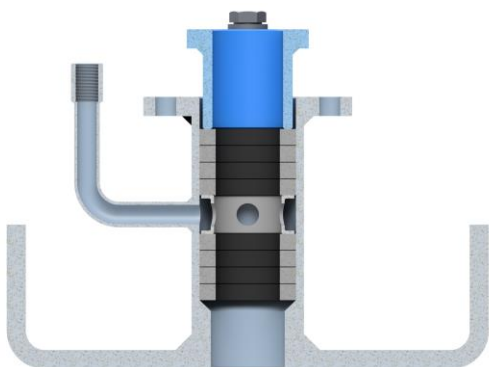

Lantern ring is a perforated hollow ring. It is placed between packing rings in each set and it extends the life of packing offering maximum corrosion resistance.

## BRAID PACKING PURGING PORTS SHAFT CLEANING CODE SS04

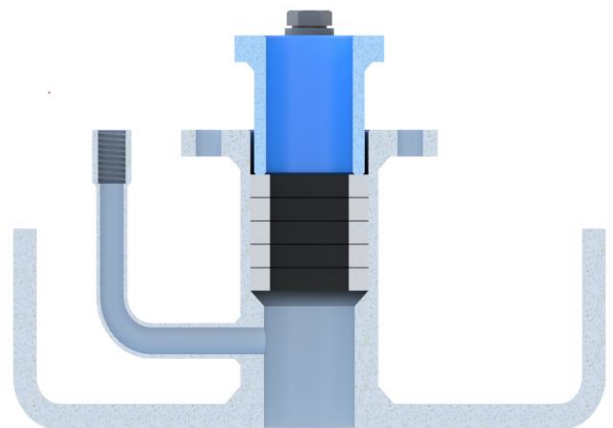

The Shaft Seal Air Purge Kit provides compressed air to the shaft seals, keeping these areas clear of material buildup.

# DIMENSIONAL DRAWINGS Type CSM11:

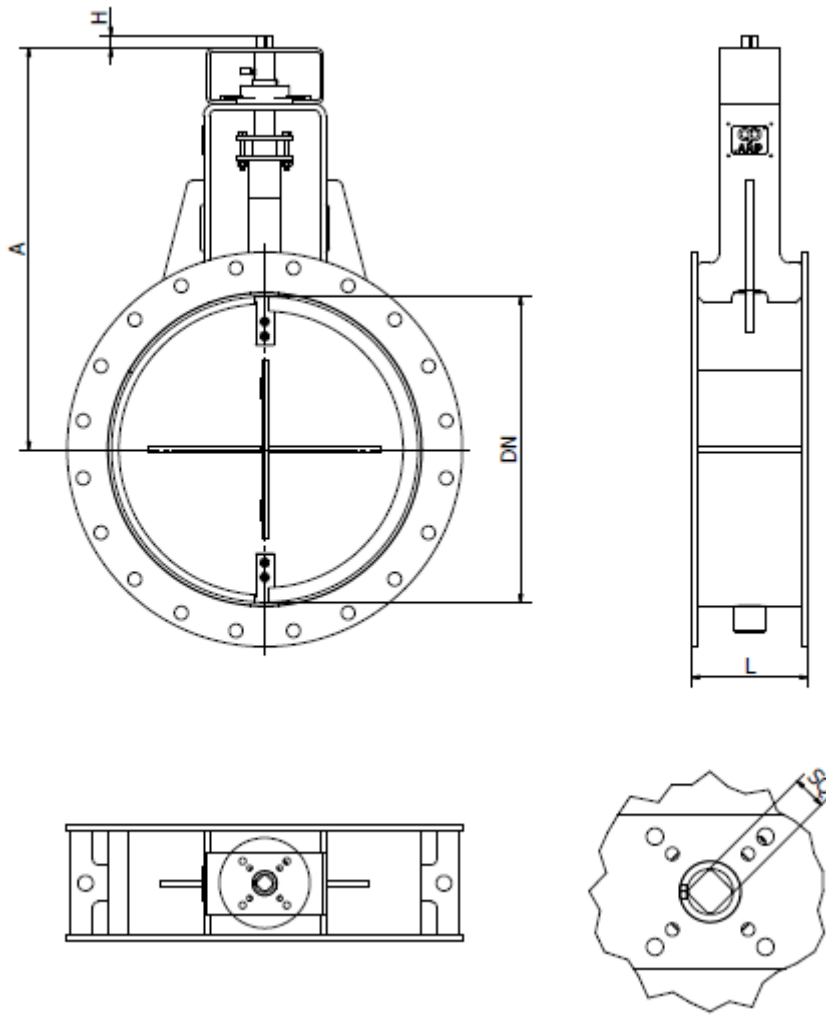

DN		Ø Int	A	L	SQ	H	TOP FLANGE ISO 5211		WEIGHT		Max diff. Press. [bar]	Torque +40%
mm	inch						FLANGED	WAFER				
150	6	160.3	441	140	14	17	F07	F05	15	14	3	24
200	8	211.1	467	140	14	17	F07	F05	18	17	3	29
250	10	265.8	493	140	14	17	F07	F05	22	20	3	35
300	12	315.9	518	140	14	17	F07	F05	26	24	2	44
350	14	350	535	140	14	17	F07	F05	29	26	1	50
400	16	400	560	140	22	22	F07	F05	34	31	1	57
450	18	450	613	190	22	22	F10	F07	48	45	1	65
500	20	500	655	190	22	22	F10	F07	34	30	1	72
600	24	600	705	190	22	22	F10	F07	76	68	0.5	87
700	28	700	766	190	22	22	F10	F07	100	90	0.5	106
800	32	800	827	190	27	27	F10	F07	125		0.5	127
900	36	900	890	240	27	27	F14	F12	149		0.2	152
1000	40	1000	953	240	27	27	F14	F12	173		0.2	179
1100	44	1100	1015	240	27	27	F14	F12	225		0.2	211
1200	48	1200	1078	240	27	27	F14	F12	278		0.2	248
1300	52	1300	1132	240	27	27	F14	F12	317		0.2	291
1400	56	1400	1187	240	27	27	F14	F12	356		0.1	326
1500	60	1500	1272	240	27	27	F14	F12	382		0.1	383

\*ARP INDUSTRY reserves the right to make changes to its products at any time

\* DN above 1500 available upon request

# FLOW COEFFICIENT (Kv VALUE) Type CSM11:

DN	NPS	OPENING ANGLE								
		90°	80°	70°	60°	50°	40°	30°	20°	10°
150	6"	1333	1135	804	513	327	191	103	49	9
200	8"	2394	2111	1463	887	608	356	215	99	19
250	10"	3813	3391	2292	1464	942	516	287	129	33
300	12"	5890	5026	3506	2268	1489	908	518	218	50
350	14"	7603	6525	4739	2978	1859	1074	651	267	57
400	16"	10118	8599	6248	3860	2423	1480	838	374	67
450	18"	12418	10681	8066	5196	3119	1763	1127	480	94
500	20"	16259	13476	10157	6402	4159	2344	1359	562	119
600	24"	23723	20259	14033	9341	5736	3510	2109	865	287
700	28"	32795	28048	19211	12448	8002	4835	2886	1171	489
800	32"	42761	37582	25226	17263	11669	6052	3628	1696	613
900	36"	54547	48690	32396	21254	14302	7582	4541	2095	778
1000	40"	74106	63582	41957	27737	18248	10656	5844	2565	1067
1100	44"	85838	70359	47849	31522	20432	12659	6932	3150	1165
1200	48"	96015	78125	56283	37353	23879	15236	8621	3534	1337
1300	52"	108116	90222	64750	41961	26410	15883	9316	4309	1524
1400	56"	124200	104740	71263	47593	28386	16896	10222	5353	1641
1500	60"	155757	129985	90178	59602	37208	22551	13094	6218	2163

Flow rate of air at 20°C and atmospheric downstream pressure (P<sub>2</sub>):

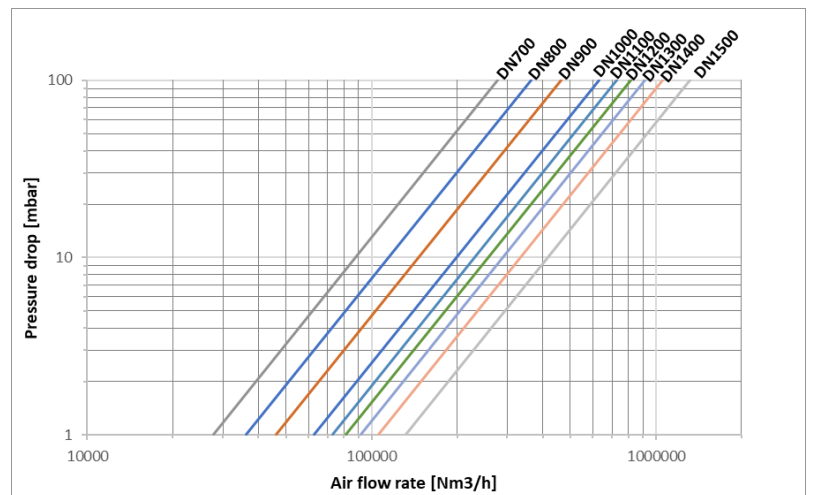
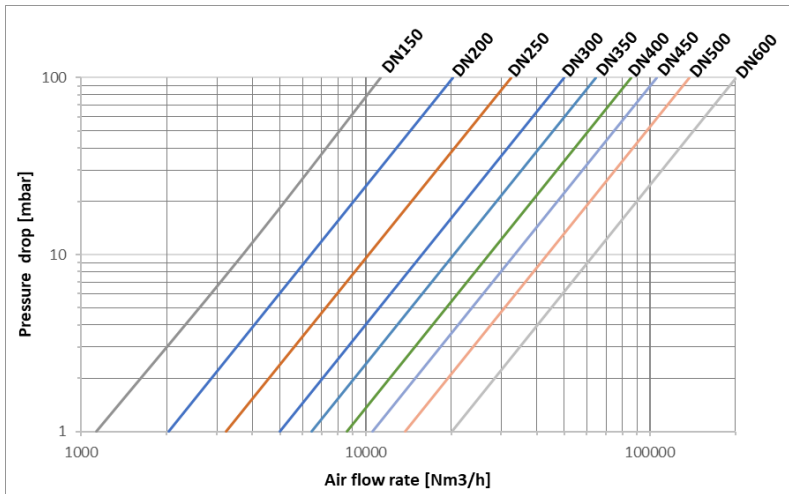

The pressure drop across the valve can be calculated with the following formula:

$$\Delta p = \frac{Q_N^2 \cdot S \cdot G_N \cdot T_1}{Kv^2 \cdot 457^2 \cdot p_2} \quad (\text{Valid for } P_2 \geq P_1/2)$$

Q<sub>N</sub> [Nm<sup>3</sup>/h] is the volumetric flow  
 Kv is the flow coefficient for a given disc position  
 S.G.<sub>N</sub> is the specific gravity of the gas (relative to air)

P<sub>1</sub> [bar] is the fluid absolute upstream pressure  
 p<sub>2</sub> [bar] is the fluid absolute downstream pressure  
 T<sub>1</sub> [K] is the fluid absolute temperature at the valve inlet



# EXPLODED VIEW Type CSM11:

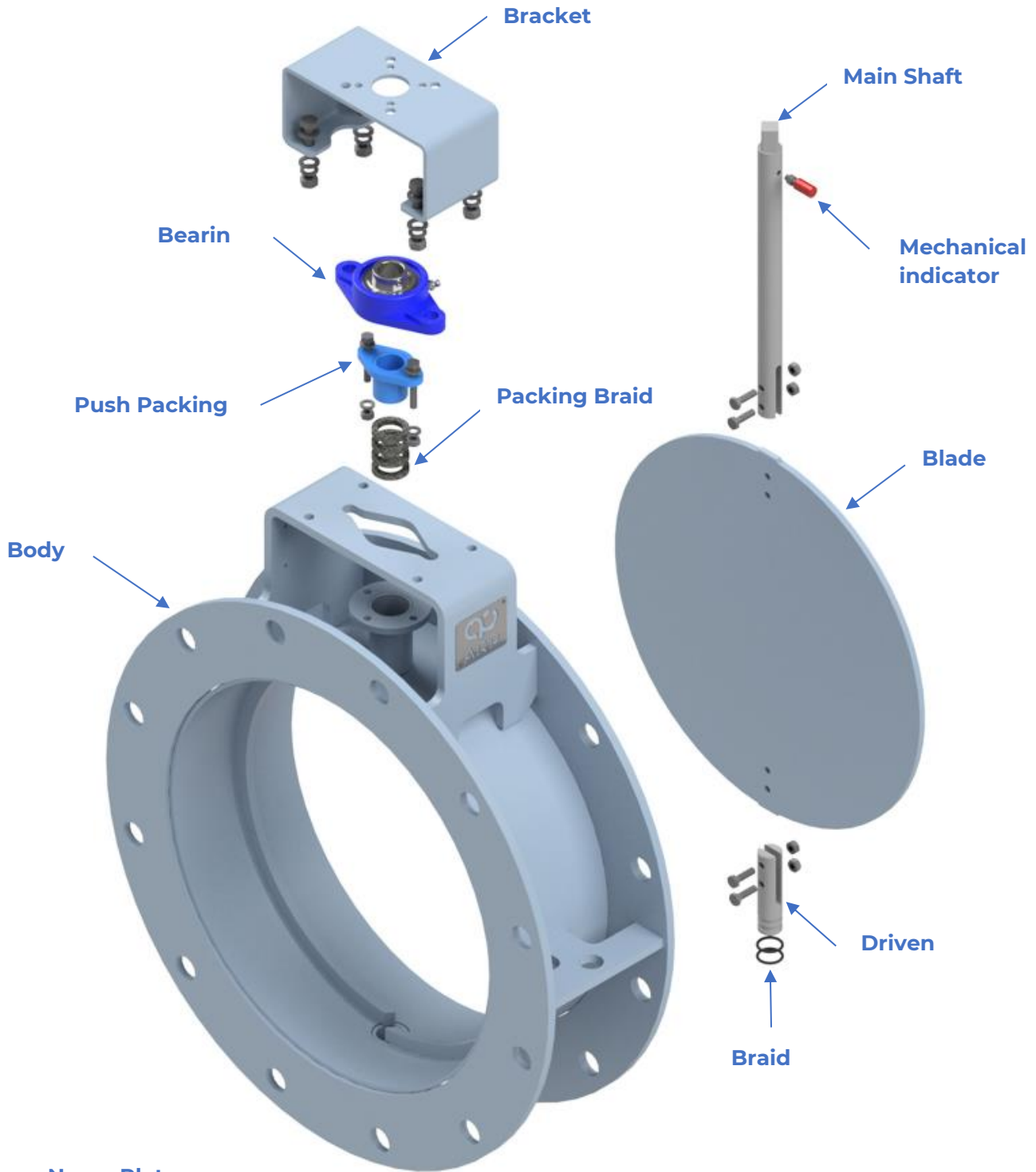

## Name Plate

		www.arpindustry.com	
TYPE:		YEAR:	
SERIAL NUMBER:		DN:	
END CONNECTION:			
Max Ts [°C]:		Max Ps [barg]:	
BODY:		DISC:	
SHAFT:		SEAT:	
PUSH PACKING:			
TAG:		CE	

# DIMENSIONAL DRAWINGS Type CSM21:

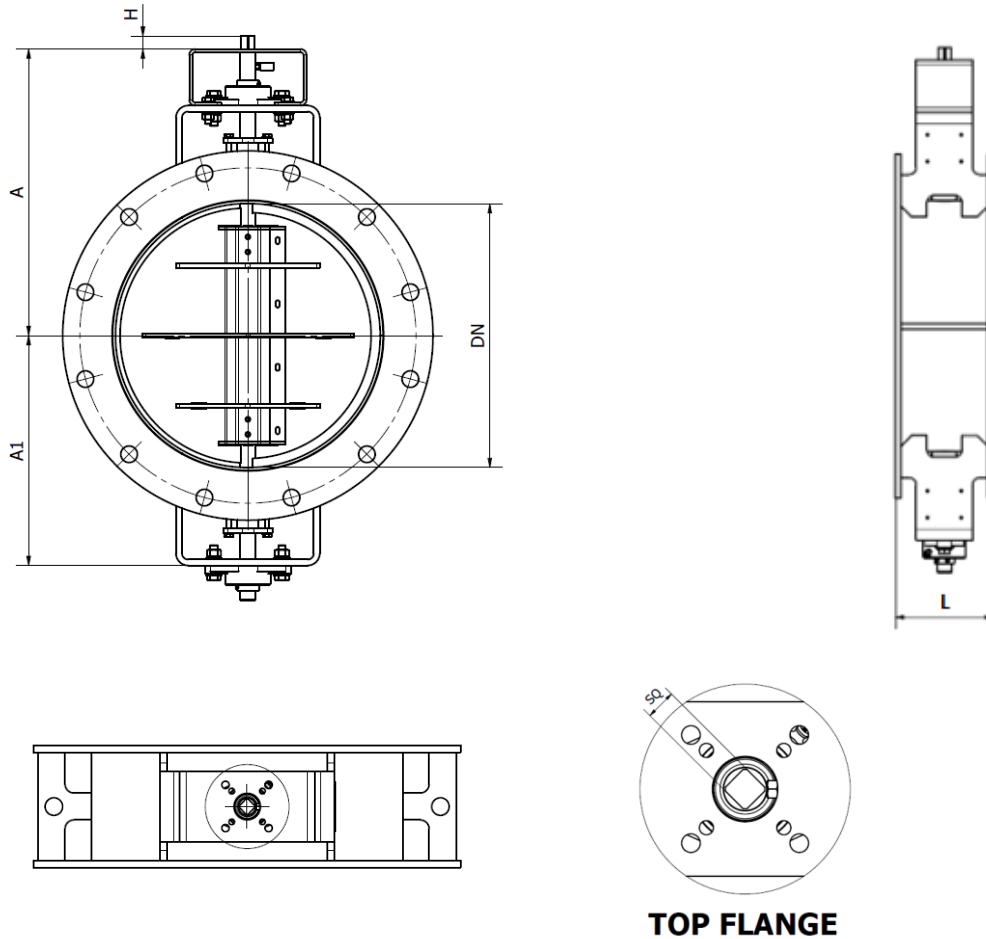

**TOP FLANGE**

DN		Ø Int	A	A1	L	SQ	H	TOP FLANGE		WEIGHT	Max diff. Press. [bar]	Torque +40% [Nm]
mm	inch							ISO 5211	FLANGED			
150	6	160.3	441	381	140	14	17	F07	F05	23	3	32
200	8	211.1	467	407	140	14	17	F07	F05	26	3	42
250	10	265.8	493	433	140	14	17	F07	F05	29	3	50
300	12	315.9	518	458	140	14	17	F07	F05	33	2	59
350	14	350	535	475	140	14	17	F07	F05	37	1	64
400	16	400	560	500	140	22	22	F07	F05	65	1	73
450	18	450	613	528	190	22	22	F10	F07	78	1	80
500	20	500	655	570	190	22	22	F10	F07	84	1	88
600	24	600	705	620	190	22	22	F10	F07	99	0.5	105
700	28	700	766	681	190	22	22	F10	F07	160	0.5	125
800	32	800	827	742	190	27	27	F10	F07	184	0.5	154
900	36	900	890	775	240	27	27	F14	F12	213	0.2	179
1000	40	1000	953	838	240	27	27	F14	F12	237	0.2	209
1100	44	1100	1015	900	240	27	27	F14	F12	314	0.2	242
1200	48	1200	1078	963	240	27	27	F14	F12	363	0.2	280
1300	52	1300	1132	1017	240	27	27	F14	F12	400	0.2	325
1400	56	1400	1187	1072	240	27	27	F14	F12	448	0.1	361
1500	60	1500	1272	1157	240	27	27	F14	F12	490	0.1	420

\*ARPINDUSTRY reserves the right to make changes to its products at any time

\* DN above 1500 available upon request

# FLOW COEFFICIENT (Kv VALUE) Type CSM21:

DN	NPS	OPENING ANGLE								
		90°	80°	70°	60°	50°	40°	30°	20°	10°
150	6"	1297	1105	782	500	318	186	100	47	9
200	8"	2338	2062	1430	866	594	348	210	97	18
250	10"	3712	3301	2232	1425	917	503	279	126	32
300	12"	5752	4908	3423	2214	1454	886	505	213	49
350	14"	7407	6356	4617	2901	1811	1047	634	260	56
400	16"	9929	8438	6130	3788	2377	1452	822	367	65
450	18"	12096	10404	7857	5062	3038	1717	1097	468	92
500	20"	15829	13119	9888	6232	4049	2282	1323	547	115
600	24"	23178	19793	13710	9126	5604	3429	2061	845	280
700	28"	32163	27507	18841	12209	7848	4742	2831	1149	479
800	32"	42009	36922	24782	16960	11464	5945	3565	1667	602
900	36"	53659	47897	31868	20908	14069	7459	4467	2061	765
1000	40"	72818	62477	41227	27255	17931	10471	5743	2521	1048
1100	44"	84196	69013	46934	30919	20041	12417	6799	3090	1143
1200	48"	94765	77108	55550	36867	23568	15038	8509	3487	1320
1300	52"	105859	88339	63399	41086	25859	15551	9122	4219	1492
1400	56"	121775	102696	69872	46664	27832	16566	10022	5248	1609
1500	60"	153793	128347	89041	58851	36739	22266	12929	6140	2136

Flow rate of air at 20°C and atmospheric downstream pressure (P<sub>2</sub>):

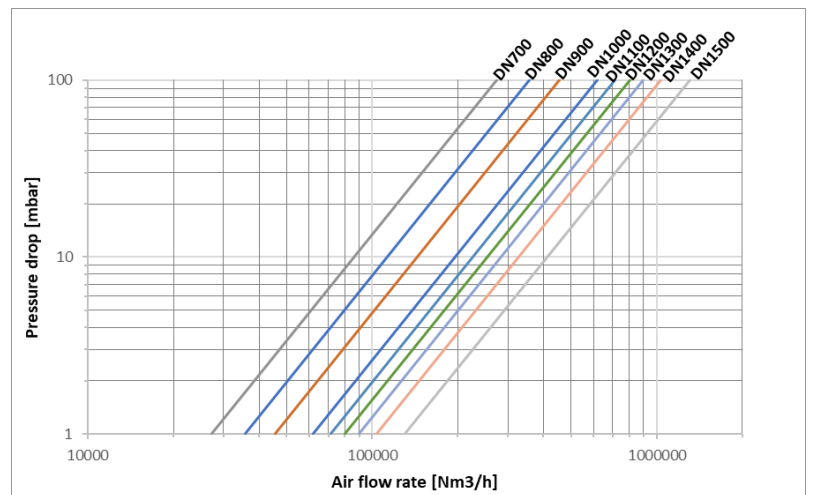
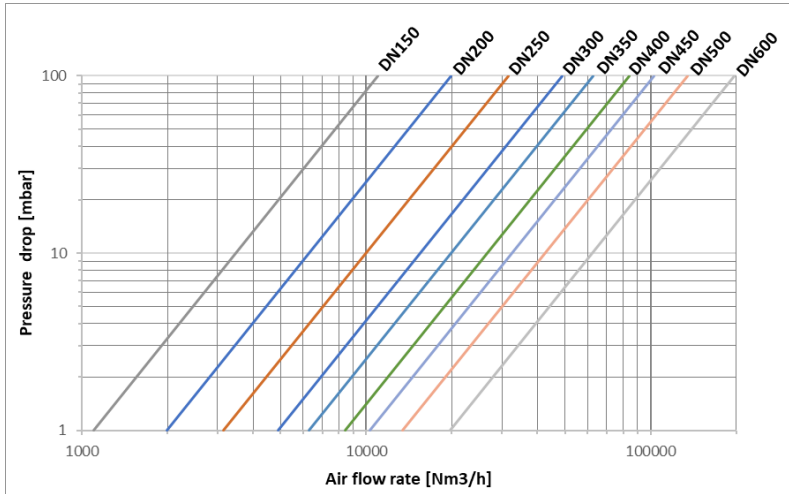

The pressure loss across the valve can be calculated with the following formula:

$$\Delta p = \frac{Q_N^2 \cdot S \cdot G_N \cdot T_1}{Kv^2 \cdot 457^2 \cdot p_2} \quad (\text{Valid for } P_2 \geq P_1/2)$$

Q<sub>N</sub> [Nm<sup>3</sup>/h] is the volumetric flow

Kv is the flow coefficient for a given disc position

S.G.<sub>N</sub> is the specific gravity of the gas (relative to air)

P<sub>1</sub> [bar] is the fluid absolute upstream pressure

p<sub>2</sub> [bar] is the fluid absolute downstream pressure

T<sub>1</sub> [K] is the fluid absolute temperature at the valve inlet

# EXPLODED VIEW Type CSM21:

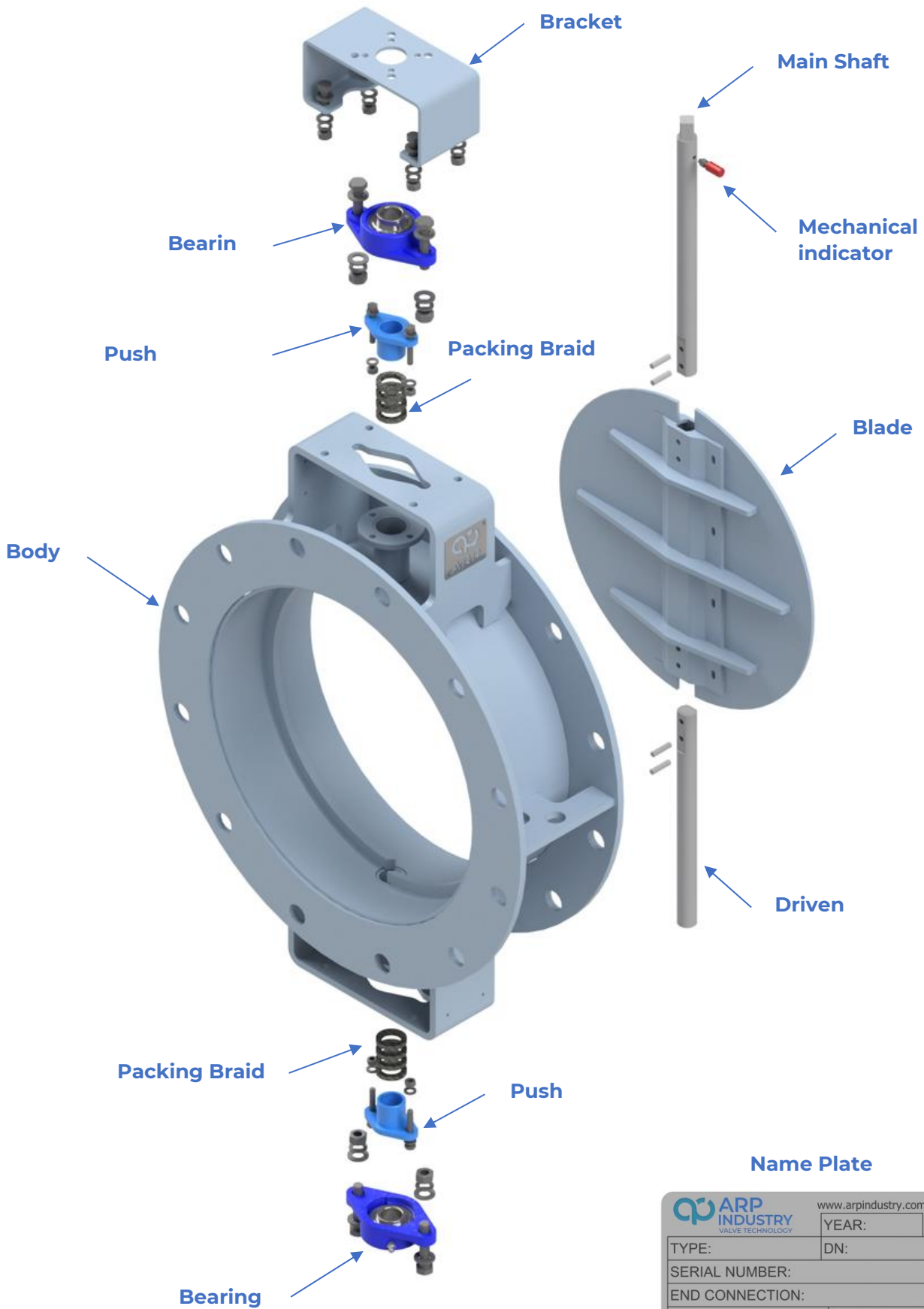

## Name Plate

		www.arpindustry.com	
TYPE:		YEAR:	
SERIAL NUMBER:		DN:	
END CONNECTION:			
Max Ts [°C]:		Max Ps [barg]:	
BODY:		DISC:	
SHAFT:		SEAT:	
PUSH PACKING:			
TAG:		CE	

# CONTACT



# ARP INDUSTRY VALVE TECHNOLOGY

**HEADQUARTERS:**

VIA INIGO CAMPIONI N°115

55100 LUCCA, ITALY

VAT N°: IT 03906880541

**E-MAIL:**

[info@arpindustry.com](mailto:info@arpindustry.com)

[e.chelini@arpindustry.com](mailto:e.chelini@arpindustry.com)

**WEBSITE:**

[www.arpindustry.com](http://www.arpindustry.com)

**MANUFACTURING PLANT:**

VIA DEL POGGIONE N°7

55023 DIECIMO, LUCCA, ITALY

**MOBILE:** +39 334 6827812

**TELEPHONE:** +39 0583 569160